

## 1.25Gb/s SFP 1310nm 40km Industrial Type

### PRODUCT FEATURES

- Transceiver unit with independent
- FP laser transmitter and PIN photo-detector
- Dual Data-rate of 1.25Gbps/1.0625Gbps Operation
- Up to 40KM transmission distance on 9/125 $\mu$ m SMF
- Standard serial ID information compliant with SFP MSA
- SFP MSA package with duplex LC connector
- Digital Diagnostic Monitor Interface
- Very low EMI and excellent ESD protection
- +3.3V single power supply
- Wide operating temperature range
- RoHS compliant
- Case operating temperature
  - Commercial: 0°C to +70°C
  - Extended: -10°C to +80°C
  - Industrial: -40°C to +85°C

### APPLICATIONS

- Switch/Router
- SAN/Server
- Other optical transmission systems

### STANDARD

- SFP MSA (Version Sept.14 2000) compliant
- SFF-8472 (Rev 9.3, Aug. 2002) Digital Diagnostic Monitoring Interface for Optical Transceivers compliant
- IEEE 802.3z compliant
- ANSI specifications for Fiber Channel compliant
- Telcordia GR-468-CORE compliant

### ORDERING INFORMATION

Product Part Number	Data Rate	Media	Wavelength	Transmission Distance	Temperature Range (Tcase)
ZSFP3112-LD40	1.25	SMF	1310	40Km	0~70°C
ZSFP3112-ILD40	1.25	SMF	1310	40Km	-40~+85°C

### ABSOLUTE MAXIMUM RATINGS

Parameter	Symbol	Min.	Max	Unit	Notes
Supply Voltage	Vcc	-0.5	3.60	V	
Storage Temperature		-40	85	°C	
Relative Humidity		5	95	%	

Note: Stress in excess of the maximum absolute ratings can cause permanent damage to the module.

## GENERAL OPERATING CHARACTERISTICS

Parameter		Symbol	Min.	Typ.	Max.	Unit	Notes
Data Rate	Gigabit Ethernet			1.25		Gb/s	
	Fiber Channel			1.0625			
Supply Voltage		Vcc	3.1	3.3	3.5	V	
Supply Current		Icc			270	mA	
Operating Case Temperature		Tc	0		70	°C	
			-10		80		
			-45		85		

## FUNCTIONAL DIAGRAM

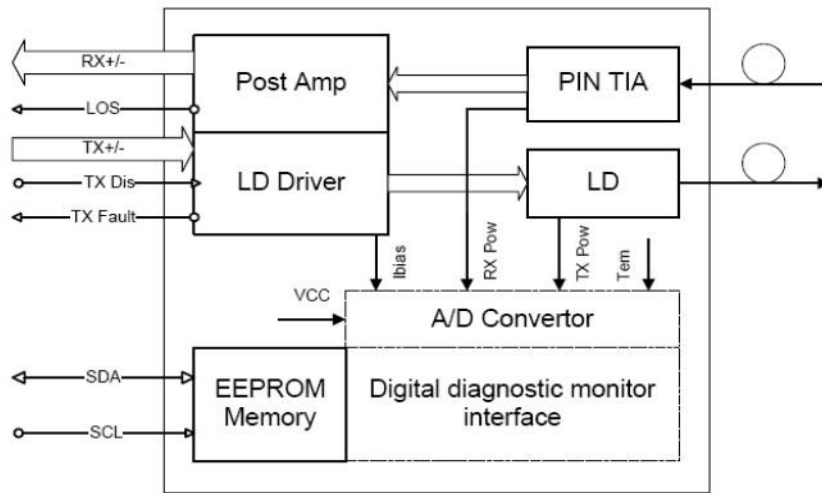

## ELECTRICAL INPUT/OUTPUT CHARACTERISTICS

Parameter	Symbol	Min.	Typ.	Max.	Unit	Notes
<b>Transmitter</b>						
Diff. Input Voltage Swing		300		1800	mVpp	1
Tx Disable Input	H	V <sub>IH</sub>	2.0	V <sub>cc</sub> +0.3	V	
	L	V <sub>IL</sub>	0	0.8		
Tx Fault Output	H	V <sub>OH</sub>	2.0	V <sub>cc</sub> +0.3	V	2
	L	V <sub>OL</sub>	0	0.8		
Input Diff. Impedance	Z <sub>in</sub>		100		Ω	
<b>Receiver</b>						
Parameter	Symbol	Min.	Typ.	Max.	Unit	Notes
Diff. Output Voltage Swing		400		1000	mVpp	3
Rx LOS Output	H	V <sub>OH</sub>	2.0	V <sub>cc</sub> +0.3	V	2
	L	V <sub>OL</sub>	0	0.8		

Note 1) TD+/- are internally AC coupled with 100Ω differential termination inside the module.

Note 2) Tx Fault and Rx LOS are open collector outputs, which should be pulled up with 4.7k to 10kΩ resistors on the host board. Pull up voltage between 2.0V and V<sub>cc</sub>+0.3V.

Note 3) RD+/- outputs are internally AC coupled, and should be terminated with 100Ω (differential) at the user SERDES.

### OPTICAL CHARACTERISTICS

Parameter	Symbol	Min.	Type	Max.	Unit	Notes
<b>Transmitter</b>						
Ave. Output Power (Enable)	Po	-6		1	dBm	1
Total Jitter	1.25G			0.431	UI	
Extinction Ratio	ER	9			dB	1
Rise/Fall Time (20%-80%)	Tr-Tf			0.26	ns	2
Wavelength Range		1270	1310	1360	nm	
Spectral Width (RMS)				1	nm	
Output Optical Eye	Compliant with IEEE802.3 z (class 1 laser safety)					
<b>Receiver</b>						
Parameter	Symbol	Min.	Type	Max.	Unit	Notes
Operating Wavelength		1270		1610	nm	
Sensitivity	Pimin			-22	dBm	3
Min. Overload	Pimax	-1			dBm	3
Total Jitter	1.25G			0.749	UI	
LOS Assert	Pa	-38			dBm	
LOS De-assert	Pd			-26	dBm	
LOS Hysteresis	Pd-Pa	0.5		6	dB	

Note 1) Measured at 1250 Mb/s with PRBS 2<sup>7</sup> - 1 NRZ test pattern.

Note 2) Unfiltered, measured with a PRBS 2<sup>7</sup>-1 test pattern @1.25Gbps

Note 3) Measured at 1250 Mb/s with PRBS 2<sup>7</sup> - 1 NRZ test pattern for BER < 1x10<sup>-12</sup>

### PIN DEFINITIONS AND FUNCTIONS

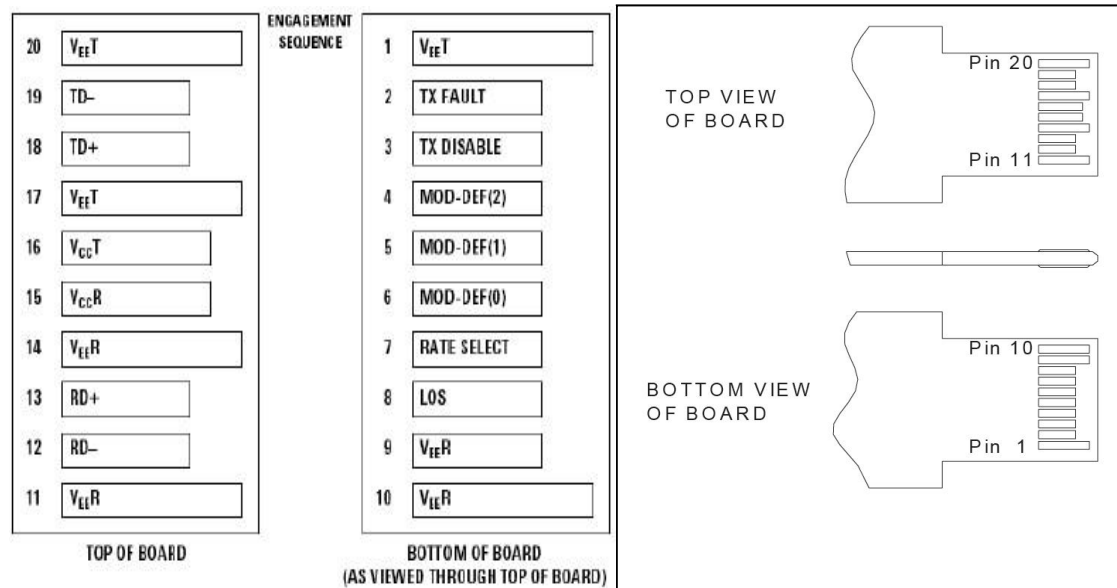

PIN #	Name	Function	Notes
1	VeeT	Tx ground	
2	Tx Fault	Tx fault indication, Open Collector Output, active “H”	Note 1
3	Tx Disable	LVTTL Input, internal pull-up, Tx disabled on “H”	Note 2
4	MOD-DEF2	2 wire serial interface data input/output (SDA)	Note 3
5	MOD-DEF1	2 wire serial interface clock input (SCL)	Note 3
6	MOD-DEF0	Model present indication	Note 3
7	Rate select	No connection	
8	LOS	Rx loss of signal, Open Collector Output, active “H”	Note 4
9	VeeR	Rx ground	
10	VeeR	Rx ground	
11	VeeR	Rx ground	
12	RD-	Inverse received data out	Note 5
13	RD+	Received data out	Note 5
14	VeeR	Rx ground	
15	VccR	Rx power supply	
16	VccT	Tx power supply	
17	VeeT	Tx ground	
18	TD+	Transmit data in	Note 6
19	TD-	Inverse transmit data in	Note 6
20	VeeT	Tx ground	

Note 1) When high, this output indicates a laser fault of some kind. Low indicates normal operation. And should be pulled up with a 4.7 – 10K $\Omega$  resistor on the host board.

Note 2) TX disable is an input that is used to shut down the transmitter optical output. It is pulled up within the module with a 4.7 – 10K $\Omega$  resistor. Its states are:

Low (0 – 0.8V): Transmitter on ( $>0.8, < 2.0V$ ): Undefined  
 High (2.0V~Vcc+0.3V): Transmitter Disabled Open: Transmitter Disabled

Note 3) Mod-Def 0,1,2. These are the module definition pins. They should be pulled up with a 4.7K – 10K $\Omega$  resistor on the host board. The pull-up voltage shall be between 2.0V~Vcc+0.3V.  
 Mod-Def 0 has been grounded by the module to indicate that the module is present  
 Mod-Def 1 is the clock line of two wire serial interface for serial ID  
 Mod-Def 2 is the data line of two wire serial interface for serial ID

Note 4) When high, this output indicates loss of signal (LOS). Low indicates normal operation.

Note 5) RD+/-: These are the differential receiver outputs. They are AC coupled 100 $\Omega$  differential lines which should be terminated with 100 $\Omega$  (differential) at the user SERDES. The AC coupling is done inside the module and is thus not required on the host board.

Note 6) TD+/-: These are the differential transmitter inputs. They are AC-coupled, differential lines with 100 $\Omega$  differential termination inside the module. The AC coupling is done inside the module and is thus not required on the host board.

### TYPICAL INTERFACE CIRCUIT

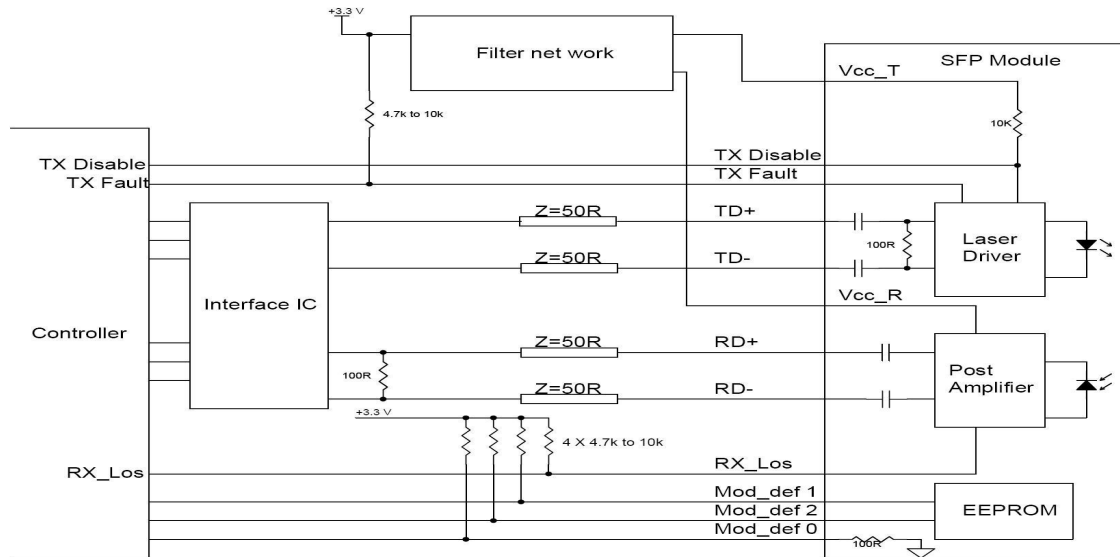

### RECOMMENDED POWER SUPPLY FILTER

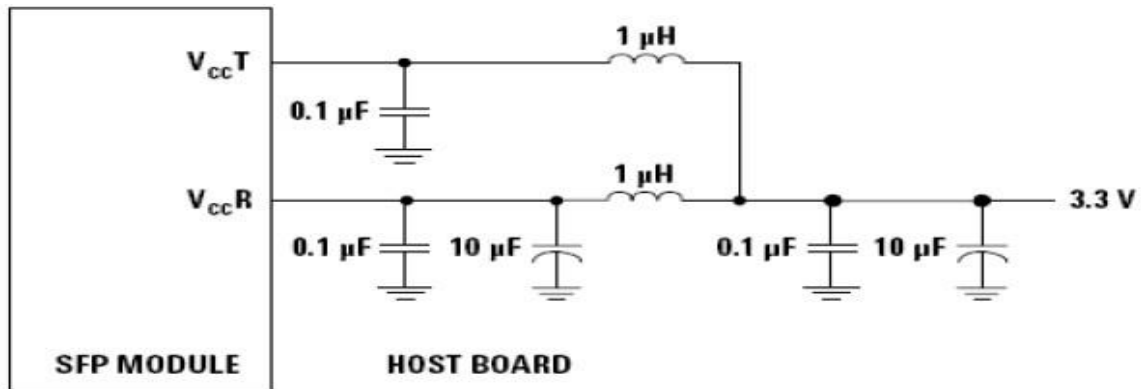

Note: Inductors with DC resistance of less than  $1\Omega$  should be used in order to maintain the required voltage at the SFP input pin with  $3.3V$  supply voltage. When the recommended supply filtering network is used, hot plugging of the SFP transceiver module will result in an inrush current of no more than  $30\text{ mA}$  greater than the steady state value.

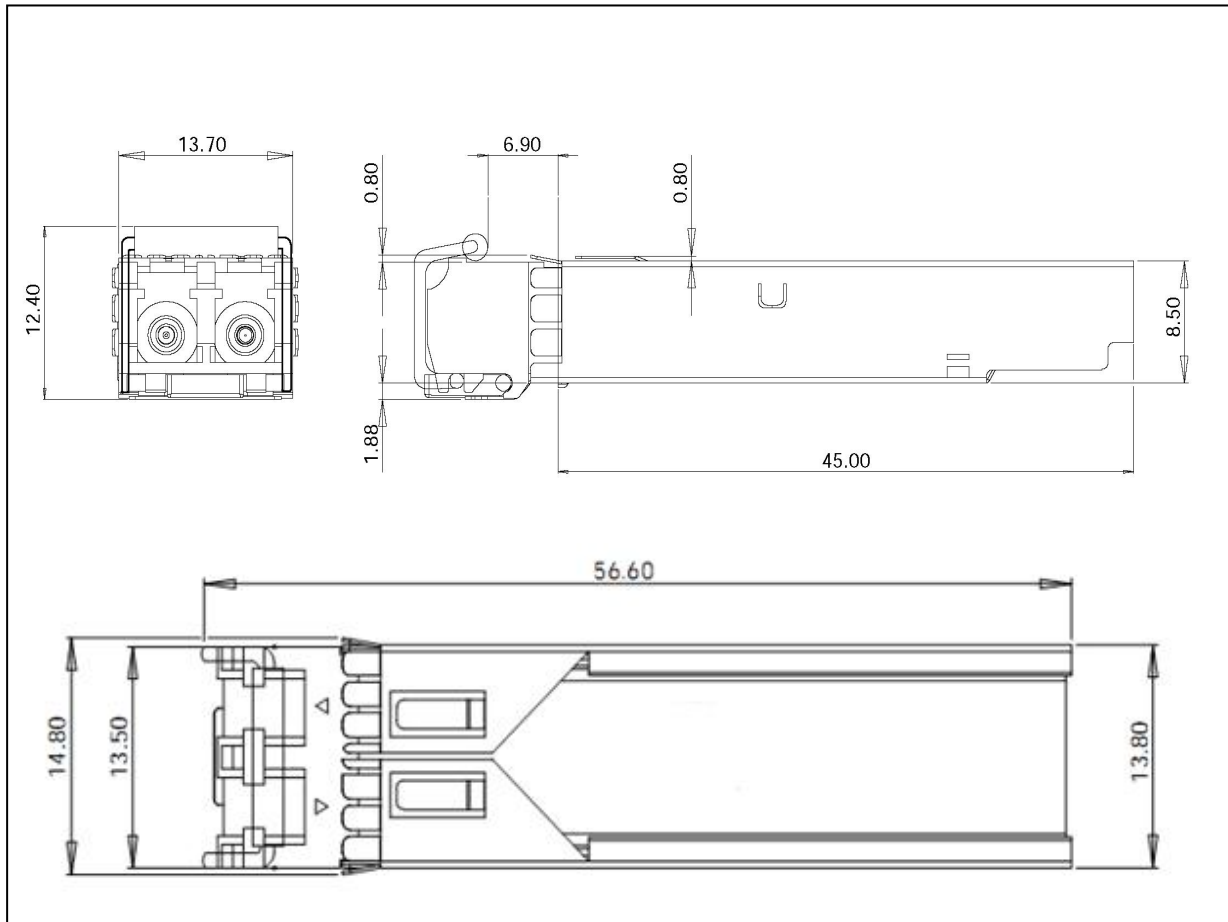
**PACKAGE DIMENSIONS**

**REGULATORY COMPLIANCE**

Feature	Reference	Performance
Electrostatic discharge (ESD)	IEC/EN 61000-4-2	Compatible with standards
Electromagnetic Interference (EMI)	FCC Part 15 Class B EN 55022 Class B (CISPR 22A)	Compatible with standards
Laser Eye Safety	FDA 21CFR 1040.10, 1040.11 IEC/EN 60825-1, 2	Class 1 laser product
Component Recognition	IEC/EN 60950, UL	Compatible with standards
ROHS	2002/95/EC	Compatible with standards
EMC	EN61000-3	Compatible with standards

**FOR MORE INFORMATION**

**Company:** Shenzhen ZiLinkOpto Co., Ltd

**Add:** 5 Floor, Tianhui Building, Donghuan 1st Road, Longhua District, Shenzhen China

**Tel:** 86-755-21004789

**Email:** sales@zilinkopto.com

**Website:** www.zilinkopto.com

Add: 5 Floor, Tianhui Building, Donghuan 1st Road, Longhua District, Shenzhen China

Tel: +86-755-21004789 Web: www.zilinkopto.com