

10Gb/s SFP 1310nm 20km Industrial Type

PRODUCT FEATURES

- SFP MSA package with duplex LC connector
- Very low EMI and excellent ESD protection
- Digital Diagnostic Monitor Interface
- Hot pluggable
- 10Gb/s serial optical interface
- Up to 20km distance
- Compliant with SFP+ MSA
- High transmission margin
- +3.3V single power supply
- Below <1W power consumption
- SFP mechanical interface

APPLICATIONS

- 10G Base-LR/LW
- 10G Fiber Channel

STANDARD

- SFP+ MSA Compliant
- SFF-8472 reversion 9.5 compliant
- IEEE802.3-2005 compliant
- Telcordia GR-468-CORE compliant
- FCC 47 CFR Part 15, Class B compliant
- FDA 21 CFR 1040.10 and 1040.11, class1 compliant
- RoHS compliant

ORDERING INFORMATION

Product Part Number	Data Rate	Media	Wavelength	Transmission Distance	Temperature Range (Tcase)
ZSFP311X-LD20	10	SMF	1310	20Km	0~70°C
ZSFP311X-iLD20	10	SMF	1310	20Km	-40~+85°C

ABSOLUTE MAXIMUM RATINGS

Parameter	Symbol	Min.	Max	Unit	Notes
Supply Voltage	Vcc	-0.5	3.60	V	
Storage Temperature		-40	85	°C	
Relative Humidity			85	%	

Note: Stress in excess of the maximum absolute ratings can cause permanent damage to the module.

GENERAL OPERATING CHARACTERISTICS

Parameter	Symbol	Min.	Typ	Max.	Unit	Note
Data Rate	Ethernet		10.3125		Gb/s	
	Fiber Channel		10.518			
Supply Voltage	V _{cc}	3.13	3.3	3.47	V	
	V _{cc}				V	
Supply Current	I _{cc5}				mA	
	I _{cc3}			350	mA	
Operating Case Temp.	T _c	0		70	°C	

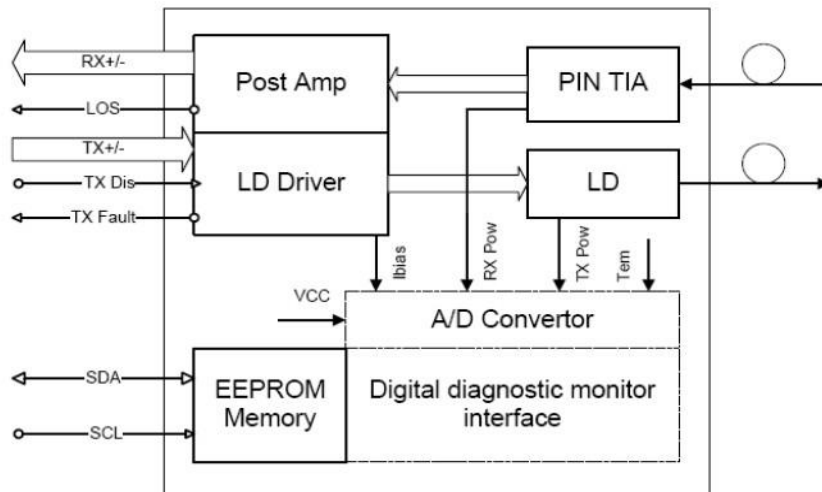
FUNCTIONAL DIAGRAM

ELECTRICAL INPUT/OUTPUT CHARACTERISTICS

Parameter	Symbol	Min.	Typ	Max.	Unit	Note
Transmitter						
Diff. input voltage swing		120		820	mV _{pp}	1
Tx Disable input	H	V _{IH}	2.0	V _{cc} +0.3	V	
	L	V _{IL}	0	0.8		
Tx Fault output	H	V _{OH}	2.0	V _{cc} +0.3	V	2
	L	V _{OL}	0	0.8		
Input Diff. Impedance	Z _{in}		100		Ω	
Receiver						
Diff. output voltage swing		340	650	800	mV _{pp}	3
Rx LOS Output	H	V _{OH}	2.0	V _{cc} +0.3	V	2
	L	V _{OL}	0	0.8		

Note 1) TD+/- are internally AC coupled with 100Ω differential termination inside the module.

Note 2) Tx Fault and Rx LOS are open collector outputs, which should be pulled up with 4.7k to 10kΩ resistors on the host board. Pull up voltage between 2.0V and V_{cc}+0.3V.

Note 3) RD+/- outputs are internally AC coupled, and should be terminated with 100Ω (differential) at the user SERDES.

OPTICAL CHARACTERISTICS

Parameter	Symbol	Min.	Typ	Max.	Unit	Note
Transmitter (0~70°C@10.3125Gb/s)						
Operating Wavelength		1290		1330	nm	
Ave. output power (Enabled)	Po	-7		0.5	dBm	1
Extinction Ratio	ER	3.5			dB	1
RMS spectral width	$\Delta\lambda$			1	nm	
Rise/Fall time (20%~80%)	Tr/Tf			50	ps	2
Optical modulation amplitude	OMA	-6.2			dBm	
Dispersion penalty				1	dB	
Output Optical Eye	IEEE 802.3-2005 Compliant					
Receiver (0~70°C@10.3125Gb/s)						
Parameter	Symbol	Min.	Typ	Max.	Unit	Note
Operating Wavelength		1290	1310	1330	nm	
Sensitivity	Psen			-14.4	dBm	3
Min. overload	Pimax	0.5			dBm	
LOS Assert	Pa	-30			dBm	
LOS De-assert	Pd			-16	dBm	
LOS Hysteresis	Pd-Pa	0.5		4	dB	

Note 1) Measured at 10.3125Gb/s with PRBS $2^{31} - 1$ NRZ test pattern.

Note 2) 20%~80%

Note 3) Under the ER worst case, measured at 10.3125 Gb/s with PRBS $2^{31} - 1$ NRZ test pattern for BER < 1×10^{-12}

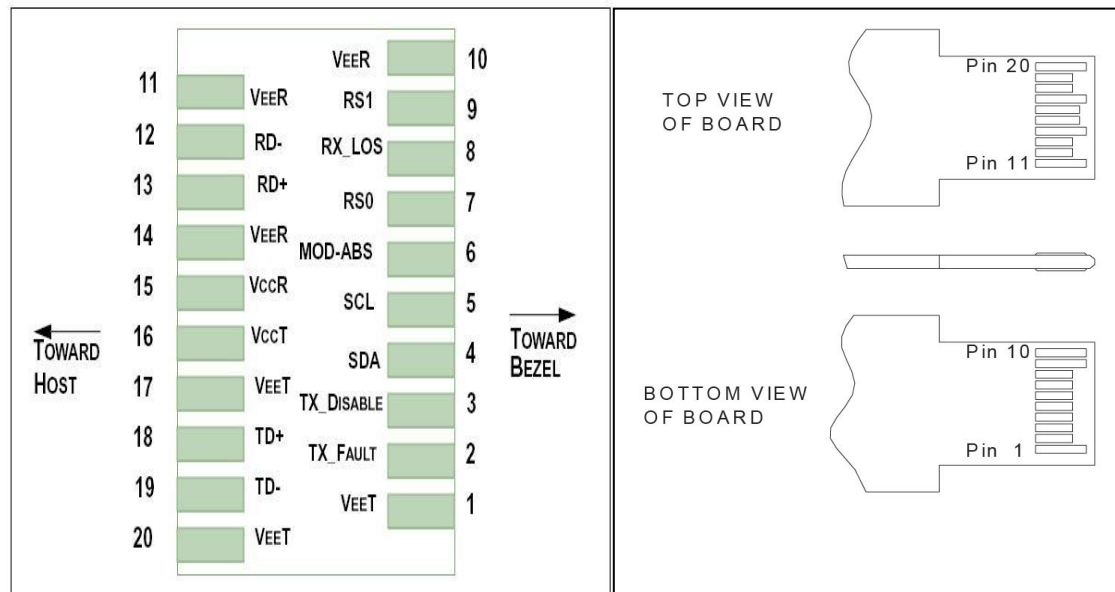
PIN DEFINITIONS AND FUNCTIONS

PIN #	Name	Function	Notes
1	VeeT	Module transmitter ground	Note1
2	Tx Fault	Module transmitter fault	Note 2
3	Tx Disable	Transmitter Disable; Turns off transmitter laser output	Note 3
4	SDL	2 wire serial interface data input/output (SDA)	
5	SCL	2 wire serial interface clock input (SCL)	
6	MOD-ABS	Module Absent, connect to VeeR or VeeT in the module	Note 2
7	RS0	Rate select0,optionally control SFP+ receiver. When high, input data rate >4.5Gb/s;when low, input data rate <=4.5Gb/s	
8	LOS	Receiver Loss of Signal Indication	Note4
9	RS1	Rate select1,optionally control SFP+ transmitter. When high, input data rate >4.5Gb/s;when low, input data rate <=4.5Gb/s	
10	VeeR	Module receiver ground	Note 1
11	VeeR	Module receiver ground	Note 1
12	RD-	Receiver inverted data out put	
13	RD+	Receiver non-inverted data out put	
14	VeeR	Module receiver ground	Note 1
15	VccR	Module receiver 3.3V supply	
16	VccT	Module transmitter 3.3V supply	
17	VeeT	Module transmitter ground	Note 1
18	TD+	Transmitter inverted data out put	
19	TD-	Transmitter non-inverted data out put	
20	VeeT	Module transmitter ground	Note1

Note 1) The module ground pins shall be isolated from the module case.

Note 2) This pin is an open collector/drain output pin and shall be pulled up with 4.7K-10Kohms to Host_Vcc on the host board.

Note 3) This pin shall be pulled up with 4.7K-10Kohms to VccT in the module.

Note 4) This pin is an open collector/drain output pin and shall be pulled up with 4.7K-10Kohms to Host_Vcc on the host board. In FC designated as RX_LOS, inSONET designated as LOS, and in Ethernet designated at Signal Detect.

TYPICAL INTERFACE CIRCUIT

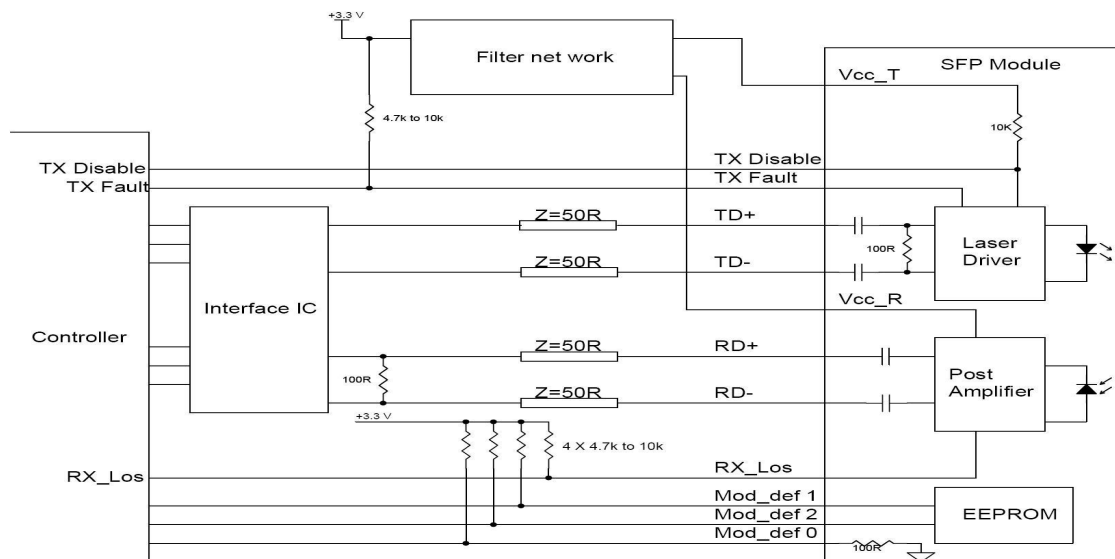

RECOMMENDED POWER SUPPLY FILTER

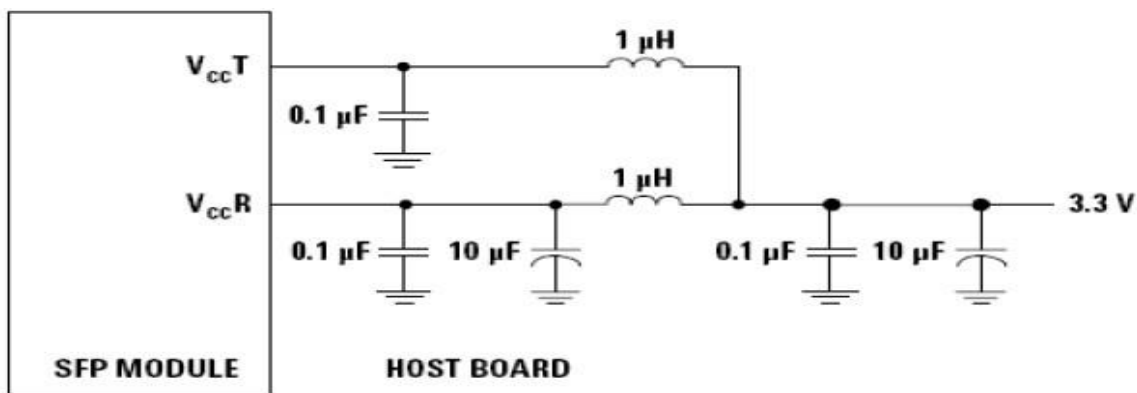

Note: Inductors with DC resistance of less than 1Ω should be used in order to maintain the required voltage at the SFP input pin with 3.3V supply voltage. When the recommended supply filtering network is used, hot plugging of the SFP transceiver module will result in an inrush current of no more than 30 mA greater than the steady state value.

PACKAGE DIMENSIONS

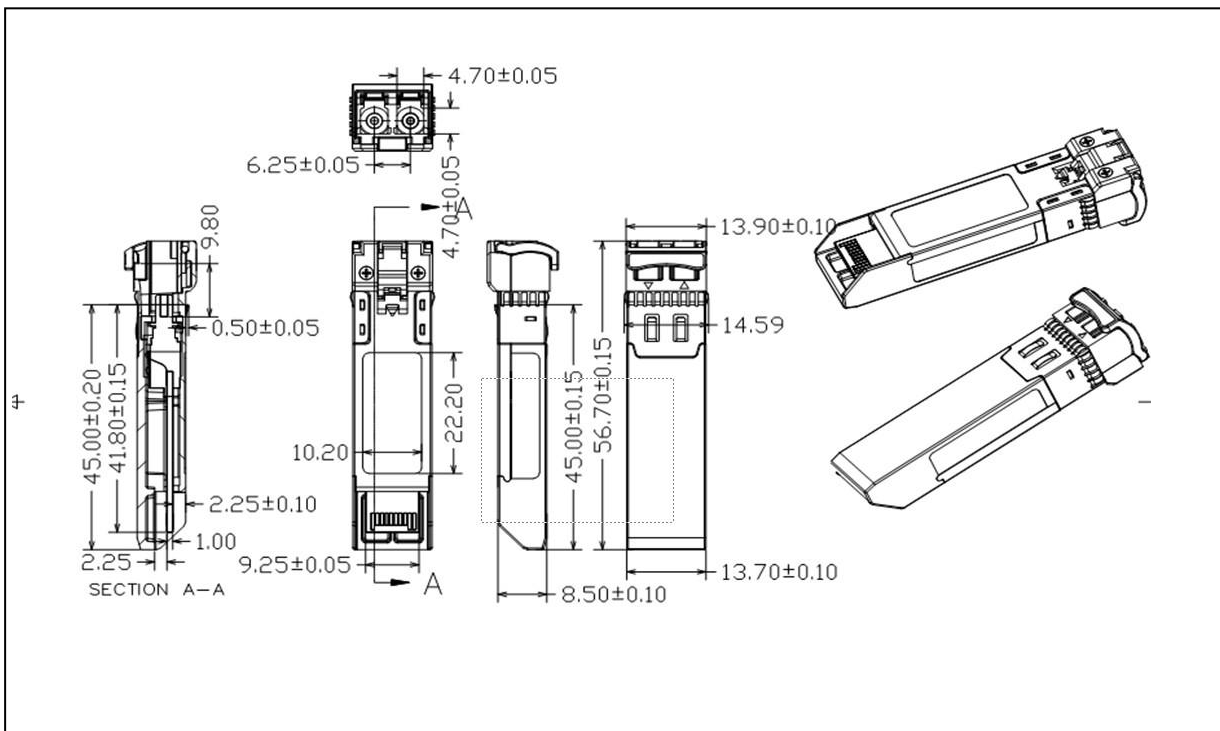

SERIAL INTERFACE FOR ID AND DDM

The SFP modules implement the 2-wire serial communication protocol as defined in the SFP MSA. The serial ID information of the SFP modules and Digital Diagnostic Monitor parameters can be accessed through the I2C interface at address A0h and A2h. The memory is mapped in Table 1. Detailed ID information(A0h) is listed in Table 2. And the DDM specification(A2h) is described in Table 3. For more details of the memory map and byte definitions, please refer to the SFF-8472 (Rev 9.3, Aug. 2002), “Digital Diagnostic Monitoring Interface for Optical Transceivers”. The DDM parameters have been internally calibrated.

Table 1. Digital Diagnostic Memory Map (Specific Data Field Descriptions)

2 wire address 1010000X (A0h)		2 wire address 1010001X (A2h)	
Address	Information	Address	Information
0~95	Serial ID Defined by SFP MSA (96 bytes)	0~55	Alarm and Warning Thresholds (56 bytes)
96~127	Vendor Specific (32 bytes)	56~95	Calibration Constants (40 bytes)
128~255	Reserved,SFF8079 (128 bytes)	96~119	Real Time Diagnostic Interface (24 bytes)
		120~127	Vender Specific (8 bytes)
		128~247	User Writable EEPROM (120 bytes)
		248~255	Vender Specific (8 bytes)

REGULATORY COMPLIANCE

Feature	Reference	Performance
Electrostatic discharge (ESD)	IEC/EN 61000-4-2	Compatible with standards
Electromagnetic Interference (EMI)	FCC Part 15 Class B EN 55022 Class B (CISPR 22A)	Compatible with standards
Laser Eye Safety	FDA 21CFR 1040.10, 1040.11 IEC/EN 60825-1, 2	Class 1 laser product
Component Recognition	IEC/EN 60950, UL	Compatible with standards
ROHS	2002/95/EC	Compatible with standards
EMC	EN61000-3	Compatible with standards

FOR MORE INFORMATION

Company: Shenzhen ZiLinkOpto Co., Ltd

Add: 5 Floor, Tianhui Building, Donghuan 1st Road, Longhua District, Shenzhen China

Tel: 86-755-21004789

Email: sales@zilinkopto.com

Website: www.zilinkopto.com