

10Gb/s XFP 1550nm 40km Industrial Type

PRODUCT FEATURES

- Hot pluggable
- Support 9.95Gb/s to 11.1Gb/s bit rates
- Below <1.5W power dissipation
- XFP MSA package with duplex LC connector
- Digital Diagnostic Monitor Interface
- Very low EMI and excellent ESD protection
- Cooled 1550nm EML laser and PIN ROSA
- Up to 40KM for single mode fiber
- operating temperature range 0°C to 70°C
- No reference clock requirement

APPLICATIONS

- 10G BASE-ER/EW Ethernet
- SONET OC-192/SDH STM-64
- Other optical links

STANDARD

- XFP MSA Compliant
- SFF-8472 reversion 9.5 compliant
- IEEE802.3-2005 compliant
- Telcordia GR-468-CORE compliant
- FCC 47 CFR Part 15, Class B compliant
- FDA 21 CFR 1040.10 and 1040.11, class I compliant
- RoHS compliant

ORDERING INFORMATION

Product Part Number	Data Rate	Media	Wavelength	Transmission Distance	Temperature Range (Tcase)
ZXFP551X-LD40	10.3125	SMF	1550	40Km	0~70°C
ZXFP551X-iLD40	10.3125	SMF	1550	40Km	-40~+85°C

ABSOLUTE MAXIMUM RATINGS

Parameter	Symbol	Min.	Max	Unit	Notes
Supply Voltage	Vcc	-0.5	4.0	V	
Storage Temperature		-40	85	°C	
Relative Humidity			85	%	

Note: Stress in excess of the maximum absolute ratings can cause permanent damage to the module.

GENERAL OPERATING CHARACTERISTICS

Parameter	Symbol	Min.	Typ	Max.	Unit	Note
Data Rate	Ethernet		10.3125		Gb/s	
	Fiber Channel		10.518			
Supply Voltage	V _{cc}	3.14	3.3	3.46	V	
	V _{cc}				V	
Supply Current	I _{cc5}				mA	
	I _{cc3}			500	mA	
Operating Case Temp.	T _c	0		70	°C	

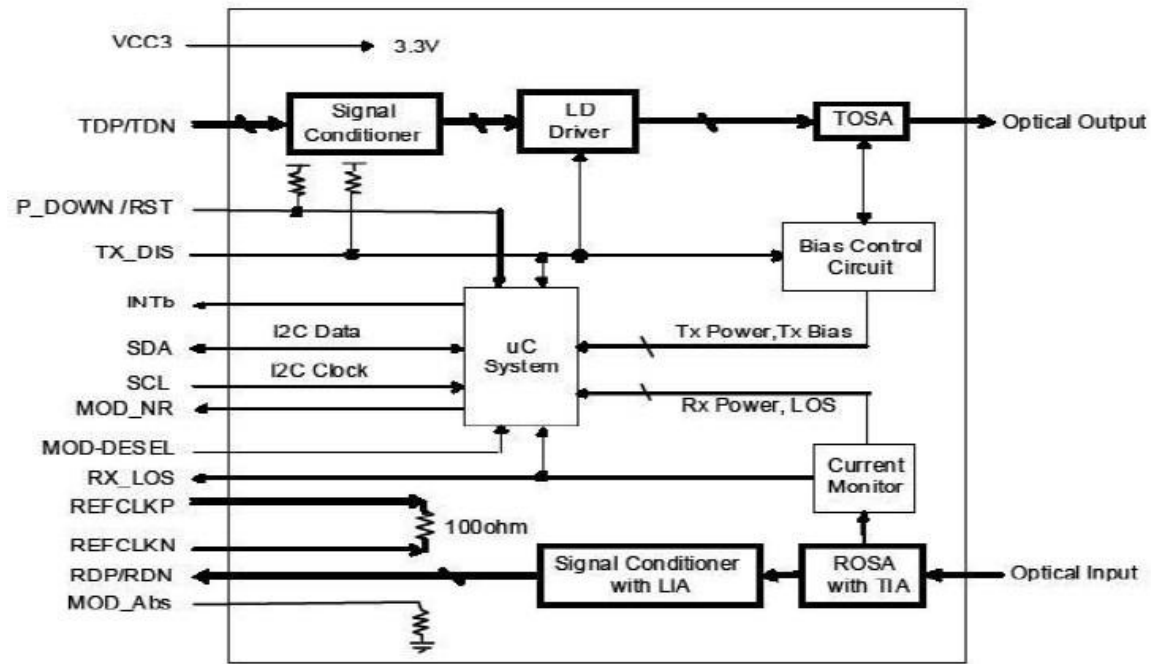
FUNCTIONAL DIAGRAM

ELECTRICAL INPUT/OUTPUT CHARACTERISTICS

Parameter	Symbol	Min.	Typ	Max.	Unit	Note
Transmitter						
Diff. input voltage swing		120		820	mVpp	1
Tx Disable input	H	V _{IH}	2.0	V _{cc} +0.3	V	
	L	V _{IL}	0	0.8		
Tx Fault output	H	V _{OH}	2.0	V _{cc} +0.3	V	2
	L	V _{OL}	0	0.8		
Input Diff. Impedance	Z _{in}		100		Ω	
Receiver						
Diff. output voltage swing		340	650	800	mVpp	3
Rx LOS Output	H	V _{OH}	2.0	V _{cc} +0.3	V	2
	L	V _{OL}	0	0.8		

Note 1) TD+/- are internally AC coupled with 100Ω differential termination inside the module.

Note 2) Tx Fault and Rx LOS are open collector outputs, which should be pulled up with 4.7k to 10kΩ resistors on the host board. Pull up voltage between 2.0V and Vcc+0.3V.

Note 3) RD+/- outputs are internally AC coupled, and should be terminated with 100Ω (differential) at the user SERDES.

OPTICAL CHARACTERISTICS

Parameter	Symbol	Min.	Typ	Max.	Unit	Note
Transmitter (0~70°C@10.3125Gb/s)						
Operating Wavelength		1530		1565	nm	
Ave. output power (Enabled)	Po	-1		+3	dBm	1
Extinction Ratio	ER	8.2			dB	1
RMS spectral width	$\Delta\lambda$			1	nm	
Rise/Fall time (20%~80%)	Tr/Tf			50	ps	2
Optical modulation amplitude	OMA	-2.1			dBm	
Dispersion penalty				2	dB	
Output Optical Eye	IEEE 802.3-2005 Compliant					
Receiver (0~70°C@10.3125Gb/s)						
Parameter	Symbol	Min.	Typ	Max.	Unit	Note
Operating Wavelength		1270		1600	nm	
Sensitivity	Psen			-16	dBm	3
Min. overload	Pimax	0.5			dBm	
LOS Assert	Pa	-30			dBm	
LOS De-assert	Pd			-18	dBm	
LOS Hysteresis	Pd-Pa	0.5		4	dB	

Note 1) Measured at 10.3125b/s with PRBS 2³¹ - 1 NRZ test pattern.

Note 2) 20%~80%

Note 3) Under the ER worst case, measured at 10.3125 Gb/s with PRBS 2³¹ - 1 NRZ test pattern for BER < 1x10⁻¹²

PIN DEFINITIONS AND FUNCTIONS

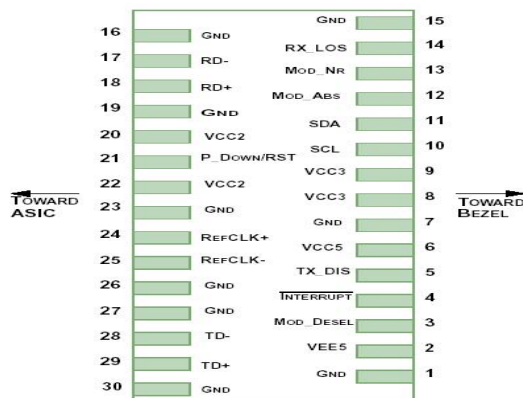

PIN #	Name	Function	Name/Description	Notes
1		GND	Module Ground	1
2		VEE5	Optional -5.2V Power Supply (Not required)	
3	LVTTL-I	MOD_DESEL	Module De-select; When held low allows the module to respond to 2-wire serial interface	
4	LVTTL-O	INTb	Interrupt; Indicates presence of an important condition which can be read via the 2-wire serial interface	2
5	LVTTL-I	TX_DIS	Transmitter Disable; Turns off transmitter laser output	
6		VCC5	+5V Power Supply (Not required)	
7		GND	Module Ground	1
8		VCC3	+3.3V Power Supply	
9		VCC3	+3.3V Power Supply	
10	LVTTL-I/O	SCL	2-Wire Serial Interface Clock	2
11	LVTTL-I/O	SDA	2-Wire Serial Interface Data Line	2
12	LVTTL-O	MOD_Abs	Indicates Module is not present. Grounded in the Module	2
13	LVTTL-O	MOD_NR	Module Not Ready; Indicating Module Operational Fault	2
14	LVTTL-O	RX_LOS	Receiver Loss Of Signal Indicator	2
15		GND	Module Ground	1
16		GND	Module Ground	1
17	CML-O	RDN	Receiver Inverted Data Output	
18	CML-O	RDP	Receiver Non-Inverted Data Output	
19		GND	Module Ground	1
20		VCC2	+1.8V Power Supply (Not required).	3
21	LVTTL-I	P_DOWN/RST	Power down; When high, requires the module to limit power consumption to 1.5W or below. 2-Wire serial interface must be functional in the low power mode.	
21	LVTTL-I	P_DOWN/RST	Reset; The falling edge initiates a complete reset of the module including the 2-wire serial interface, equivalent to a power cycle.	
22		VCC2	+1.8V Power Supply (Not required)	3
23		GND	Module Ground	1
24	PECL-I	REFCLKP	Not used, internally terminated to 50ohm (100ohm diff).	4
25	PECL-I	REFCLKN	Not used, internally terminated to 50ohm (100ohm diff).	4
26		GND	Module Ground	1
27		GND	Module Ground	1
28	CML-I	TDN	Transmitter Inverted Data Input	
29	CML-I	TDP	Transmitter Non-Inverted Data Input	
30		GND	Module Ground	1

Note:1. Module ground pins GND are isolated from the module case and chassis ground within the module.

2. Open collector; Shall be pulled up with 4.7K-10Kohms to a voltage between 3.15V and 3.6V on the

- host board.
- The pins are open within module.
 - Reference Clock is not required.

TYPICAL INTERFACE CIRCUIT

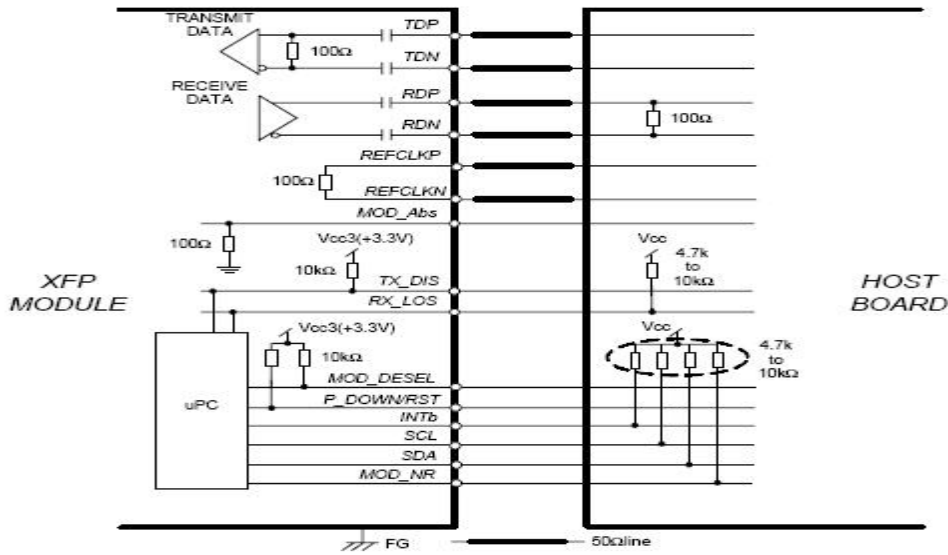

PACKAGE DIMENSIONS

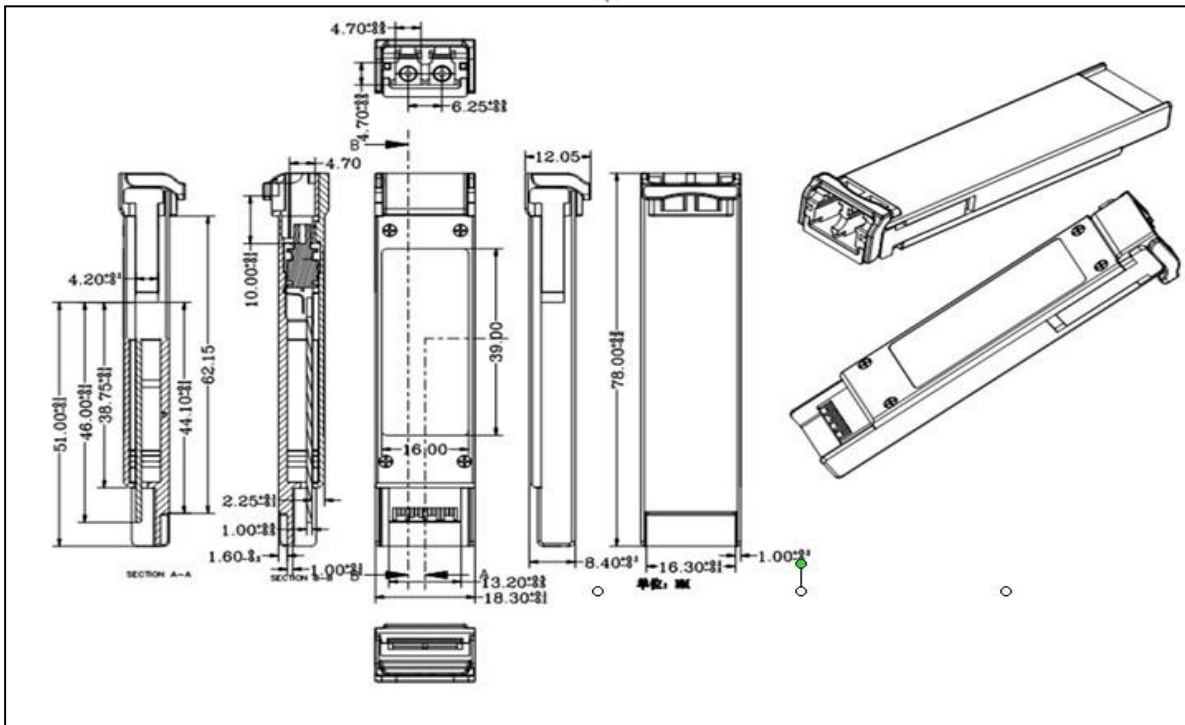

SERIAL INTERFACE FOR ID AND DDM

The XFP modules implement the 2-wire serial communication protocol as defined in the XFP MSA. The serial ID information of the XFP modules and Digital Diagnostic Monitor parameters can be accessed through the I2C interface at address A0h and A2h. The memory is mapped in Table 1. Detailed ID information(A0h) is listed in Table 2. And the DDM specification(A2h) is described in Table 3. For more details of the memory map and byte definitions, please refer to the SFF-8472 (Rev 9.3, Aug. 2002), “Digital Diagnostic Monitoring Interface for Optical Transceivers”. The DDM parameters have been internally calibrated.

Table 1. Digital Diagnostic Memory Map (Specific Data Field Descriptions)

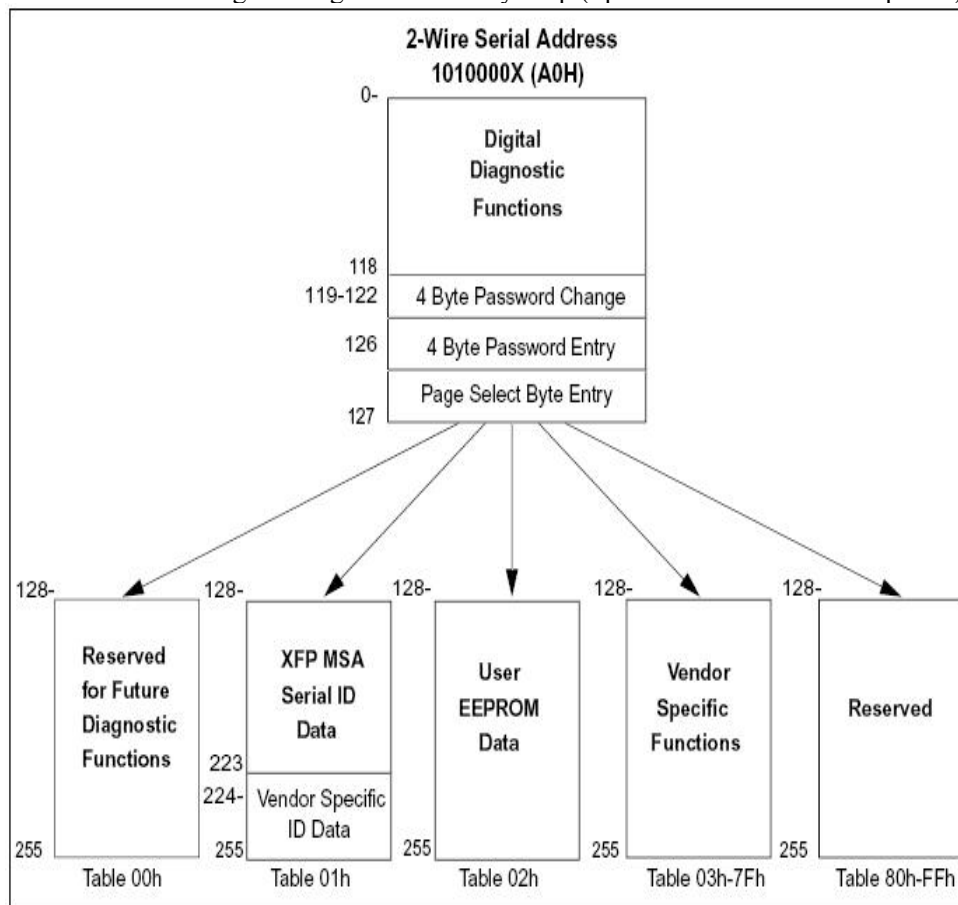

REGULATORY COMPLIANCE

Feature	Reference	Performance
Electrostatic discharge (ESD)	IEC/EN 61000-4-2	Compatible with standards
Electromagnetic Interference (EMI)	FCC Part 15 Class B EN 55022 Class B (CISPR 22A)	Compatible with standards
Laser Eye Safety	FDA 21CFR 1040.10, 1040.11 IEC/EN 60825-1, 2	Class 1 laser product
Component Recognition	IEC/EN 60950, UL	Compatible with standards
ROHS	2002/95/EC	Compatible with standards
EMC	EN61000-3	Compatible with standards

FOR MORE INFORMATION**Company:** Shenzhen ZiLinkOpto Co., Ltd**Add:** 5 Floor, Tianhui Building, Donghuan 1st Road, Longhua District, Shenzhen China**Tel:** 86-755-21004789**Email:** sales@zilinkopto.com**Website:** www.zilinkopto.com